

The Log-Yag Array

The Yagi antenna array has been around for years and years. A relative newcomer to hams is the log-periodic dipole array (LPDA), which offers nearly constant gain over a greater bandwidth than the Yagi. Guess what happens when you cross a Yagi with an LPDA . . .

By P. D. Rhodes,* K4EWG and J. R. Painter,** W4BBP

With the decline in sunspot activity, a number of amateurs have considered monoband Yagi arrays. The first problem encountered seems to be array length, that is, overall size for a desired gain and bandwidth. The Log-Yagi principle, as will be discussed shortly, has produced a system which will provide the amateur with another alternative to the long-boom Yagi, stacked Yagis, or loop-antenna systems. The L-P Yagi (Log-Yag) array is not a new system; many such arrays have been designed and developed¹ by Oliver Swan¹ and others.² This article, however, will provide the basic theory of operation, design procedure, and the construction of a practical antenna.

Theory of Operation

The Log-Yag array utilizes an LPDA³ driven group of elements, designed to cover a desired bandwidth, in conjunction with parasitic elements to achieve higher gains and greater directivity than would be realized with either the LPDA or Yagi array alone. The Yagi array requires a long boom and wide element spacing for wide bandwidth and high gain. This is because the Q of the Yagi system increases as the number of elements is increased and/or as the spacing between adjacent elements is decreased.^{4,5} An increase in the Q of the Yagi array means that the total bandwidth of that array is decreased, and optimum gain, front-to-back ratio, and side lobe rejection are obtainable only over small portions of the band. Dr. I. L. Morris, using a high-speed digital computer, has completed exten-

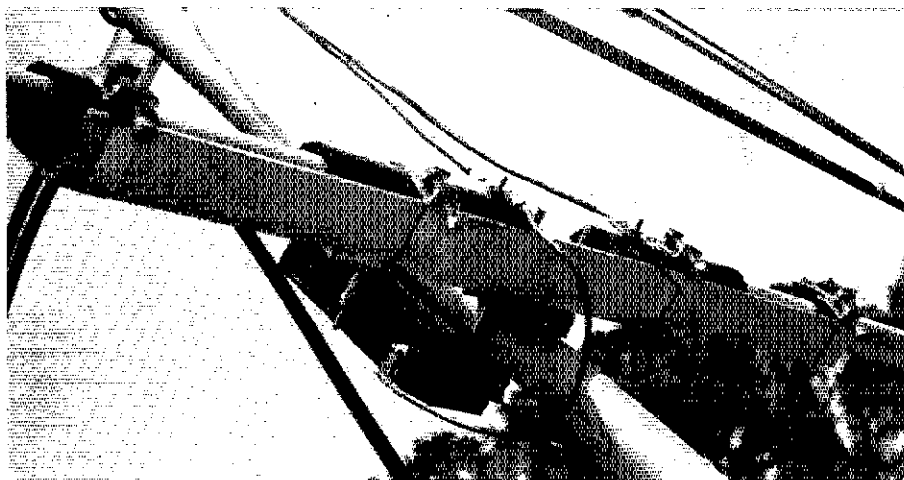

The attachment of the elements to the boom.

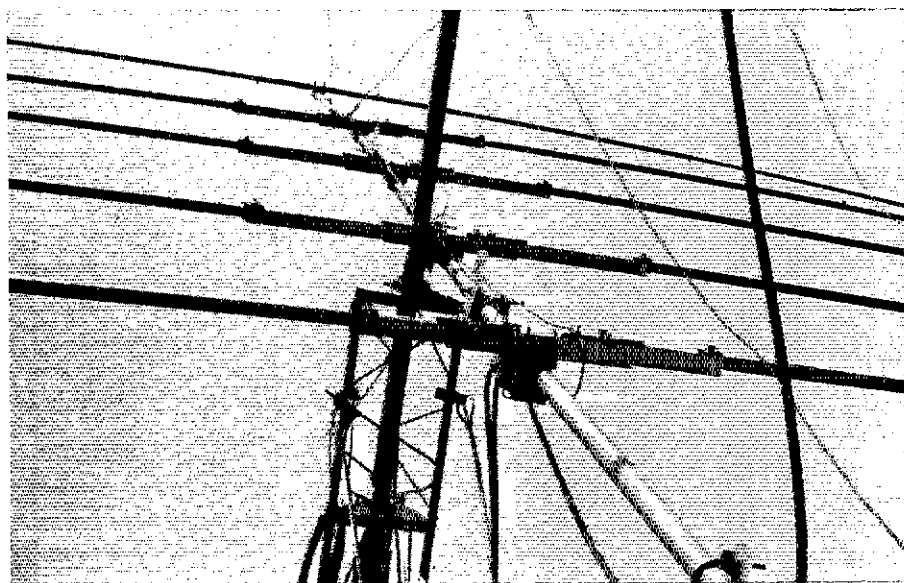

From the front to the back of the Log-Yag array. Note the truss provides lateral and vertical support.

*3125 Keenan Rd., College Park, GA 30349

**4243 Loveless Dr., Ellenwood, GA 30049

¹ References appear on page 21.

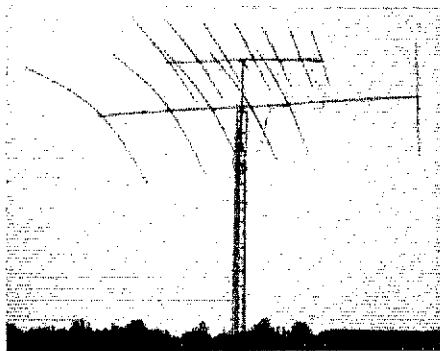

The completed Log-Yag array ready for use. The array mounted above the Log-Yag is a 7-element LPDA for 21 to 30 MHz.

sive research on four-, eight-, and ten-director Yagi-Uda arrays.⁶ His work is comprehensive and is recommended reading for all technically minded amateurs. The parameters varied in his study were element length, spacing, radius and number. As can be seen in Fig. 1, the forward gain and front-to-back ratio deteriorate sharply as element spacings decrease. If the elements are closely spaced, then as the frequency is shifted either side of the array design frequency the electrical spacing between adjacent elements changes rapidly. This causes a higher SWR and a deterioration of forward gain and front-to-back ratio.

The Log-Yagi system overcomes this difficulty by using a multiple driven element "cell" designed in accordance with the principles of the log-periodic dipole array.^{7,8} Since this log cell exhibits both gain and directivity by itself, it is a more effective radiator than a simple dipole driven element. The front-to-back ratio and gain of the log cell can be improved with the addition of a parasitic reflector and director. It is

not necessary for the parasitic element spacings to be large with respect to wavelength, as in the Yagi array, since the log cell is the determining factor in the array bandwidth. In fact, the element spacings within the log cell may be small with respect to a wavelength without appreciable deterioration of the cell gain. For example, decreasing the relative spacing constant (σ) from 0.1 to 0.5λ will decrease the gain by less than 1 dB. Hence, a further reduction in boom length. It can be seen that the Log-Yag array will exhibit high theoretical gain (11 dBd), high front-to-back ratio (30 dB), high cross polarization (front-to-side ratio - 45 dB), and a wide-band response utilizing boom lengths approximately one half that of a Yagi with similar characteristics.²

The author has built many monoband 14-MHz Log-Yag arrays in an attempt to find an optimum combination of elements, while holding the boom length to that of a full-sized 3-element monobander Yagi. Relative radiation patterns for various element combinations are found in Fig. 2. The final array design takes the form of a 4-element log cell, parasitic reflector spaced at $.085 \lambda_{max}$ and parasitic director spaced at $.15 \lambda_{max}$ where λ_{max} is the longest free-space wavelength within the array passband. It has been found that array gain is almost unaffected with reflector spacings from $.08 \lambda$ to 0.25λ and the increase in boom length is not justified.⁹ The function of the reflector is to improve the front-to-back ratio of the log cell while the director sharpens the forward lobe and decreases the half-power beamwidth. As the spacing between the parasitic elements and the log cell decreases, the parasitic elements must increase in length.¹⁰

Table 1
Array Characteristics

1. Frequency range	14 = 14.35 MHz
2. Operating bandwidth	$B = 1.025$
3. Design parameter	$\tau = .946657$
4. Apex half angle	$\alpha = 14.92^\circ$, $\cot = 3.753$
5. Half-power beam width	42° (14-14.35 MHz)
6. Bandwidth of structure	$B_s = 1.17875$
7. Free-space wavelength	$\lambda_{max} = 70.28$ ft
8. Log cell boom length	$L = 10.0$ ft
9. Longest log element	$l_1 = 35.14$ ft (a tabulation of element lengths and spacings given in Table 2)
10. Forward gain over dipole	11.5 dB (theoretical)
11. Front-to-back ratio	32 dB (theoretical)
12. Front-to-side ratio	45 dB (theoretical)
13. Input impedance	$Z_o = 37$ ohms
14. SWR	1.3 to 1 (14 - 14.35 MHz)
15. Total weight	96 pounds
16. Wind-load area	8.5 sq. ft
17. Feed-point impedance,	$Z_o = 37$ ohms
18. Reflector length	36.4 ft @ 6.0 ft spacing
19. Director length	32.2 ft @ 10.5 ft spacing
20. Total boom length	26.5 ft

The mechanical construction of the log cell is identical to that described in *The ARRL Antenna Book*, except for the lengths and spacings.^{3,7} Fig. 4 shows how the log cell is constructed as well as the addition of the parasitic elements.

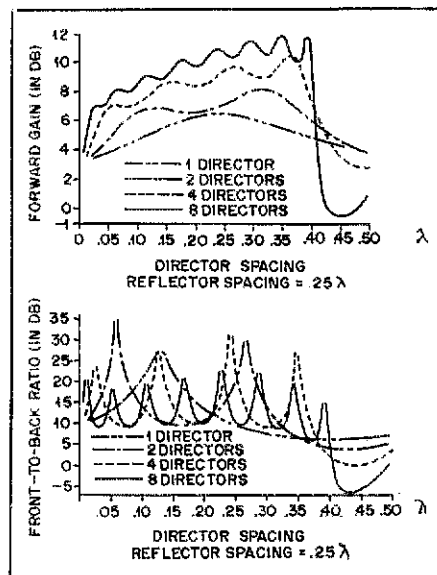

Fig. 1 — The effects of director spacing on various Yagi arrays. The change in gain and front-to-back ratio is plotted for the change in director spacing. The reflector spacing has been held constant.

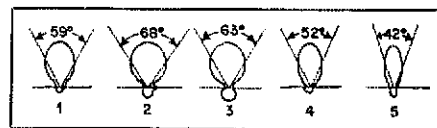

Fig. 2 — Beam patterns of 20-meter arrays.
No. 1 — 3-el. log cell, dir. @ 0.1λ , ref. @ 0.2λ .
No. 2 — 5-el. log periodic, $\sigma = 0.1$.
No. 3 — 3-el. log cell, 1st dir. @ 0.1λ , 2nd dir. @ 0.2λ .
No. 4 — 4-el. log cell, ref. @ 0.15λ .
No. 5 — 4-el. log cell, dir. @ 0.15λ , ref. @ 0.085λ (described in this article).

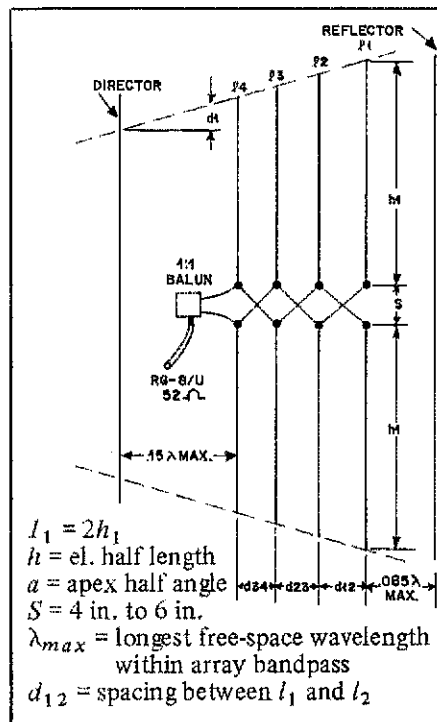

Fig. 3 — Layout of the Log-Yag array.

Table 2
Array Dimensions

ELEMENT	LENGTH FEET	SPACING FEET
Reflector	36.4	6.0 (Ref. to l_1)
l_1	35.14	3.51 (d_{12})
l_2	33.27	3.32 (d_{23})
l_3	31.49	3.14 (d_{34})
l_4	29.81	10.57 (l_4 to dir.)
Director	32.2	

The log cell is designed to meet upper and lower band limits with $\sigma = .05\lambda$. The design parameter τ is dependent on the structure bandwidth, B_s . When the log-periodic design parameters have been found, the element length and spacings can be determined. A review of the "Log-Periodic Dipole Array" is recommended though not necessary for the design of the Log-Yag array.^{3,7,8}

The method of feeding the antenna is identical to that of feeding the log-periodic dipole array without the parasitic elements. As shown in Fig. 3, a balanced feeder is required for each log-cell element, and all adjacent elements are fed with a 180° phase shift by alternating connections. Since the Log-Yag array will be covering a relatively small bandwidth, the radiation resistance of the narrow-band log cell will vary from 80 to 90 ohms (tubing elements) depending on the operating bandwidth. The addition of parasitic elements lowers the log-cell radiation resistance. Hence, it is recommended that a 1-to-1 balun be connected at the log-cell input terminals and 52-ohm coaxial cable be used for the feed line. The measured radiation resistance of the 14-MHz Log-Yag installed at the author's QTH is 37 ohms, 14.0 to 14.35 MHz. It is assumed that tubing elements will be used. However, if a wire array is

Table 3
Element Material Requirements

ELEMENT	1-IN. TUBING		7/8-IN. TUBING		3/4-IN. TUBING		1-1/4-IN. ANGLE		1 X 1/4-IN. BAR	
	LTH.	QTY.	LTH.	QTY.	LTH.	QTY.	LTH.	QTY.	LTH.	QTY.
Reflector	12	1	6	2	8	2	None		None	
l_1	6	2	6	2	8	2	3		1	
l_2	6	2	6	2	8	2	3		1	
l_3	6	2	6	2	6	2	3		1	
l_4	6	2	6	2	6	2	3		1	
Director	12	1	6	2	6	2	None		None	

used then the radiation resistance R_o and antenna-feeder input impedance Z_o must be calculated so that the proper balun and coax may be used. The procedure is outlined in detail in *The ARRL Antenna Book*.^{3,7}

Design Procedure

The following step-by-step design procedure may be used to design any monoband Log-Yag for any desired bandwidth.

1) Determine the operating bandwidth, B , between f_1 , lowest frequency (band edge), and f_n , highest frequency (band edge).

$$B = \frac{f_n}{f_1}$$

2) Determine the structure bandwidth (log-cell array) B_s .

$$B_s = 1.15B$$

3) Determine the design parameter τ (based on 4-element log cell, note 1).

$$\tau = \frac{1}{\sqrt[3]{B_s}}$$

Note 1. The design parameter τ is chosen for a four-element log cell since it provides the best bandpass for most amateur bands. For log cells with any number of elements

$$\tau = \frac{1}{(n-1)\sqrt[3]{B_s}}$$

where n = number of elements within the log cell.

4) Determine the apex half-angle α : Since $\sigma = .05$ (relative spacing constant), then

$$\cot \alpha = \frac{0.2}{1 - \tau}$$

5) Determine the longest free-space wavelength λ_{max} , log-cell boom length, L (ft) and longest element length within the log cell l_1 (ft).

$$\lambda_{max} = \frac{984}{f_1 \text{ MHz}}$$

$$L = \left[\frac{1}{4} \left(1 - \frac{1}{B_s} \right) \cot \alpha \right] \lambda_{max}$$

and

$$l_1 = \frac{492}{f_1 \text{ MHz}}$$

$$l_2 = \tau l_1$$

$$l_3 = \tau l_2$$

$$l_4 = \tau l_3$$

6) Determine the element spacing (d_{12}), distance between elements l_1 and l_2 (ft.).

$$d_{12} = \frac{1}{2} (l_1 - l_2) \cot \alpha$$

and

$$d_{23} = \tau d_{12}$$

$$d_{34} = \tau d_{23}$$

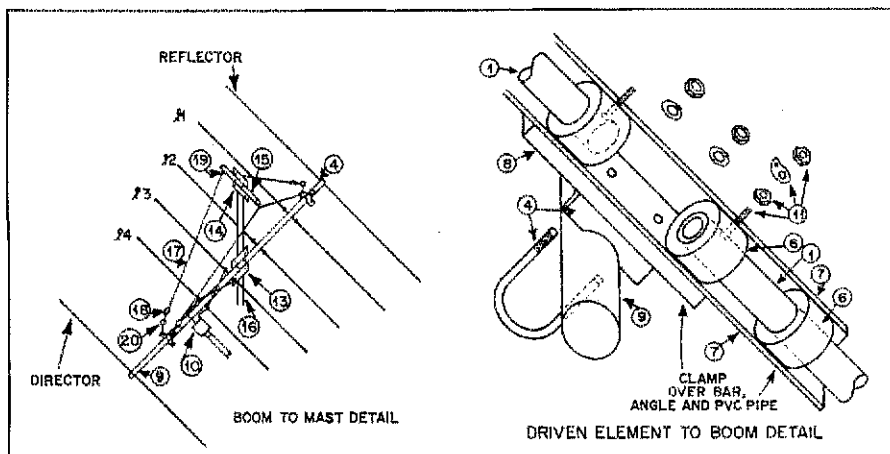

Fig. 4 — Assembly details. The numbered components refer to Table 4.



The connections between the balun and l_4 .

Table 4
Materials List

1. Aluminum tubing — .047 in. wall thickness
1 in. — 12 ft lengths, 24 lin. ft
1 in. — 12 ft or 6 ft lengths, 48 lin. ft
7/8 in. — 12 ft or 6 ft lengths, 72 lin. ft
3/4 in. — 8 ft lengths, 48 lin. ft
3/4 in. — 6 ft lengths, 36 lin. ft
2. Stainless steel hose clamps — 2 in. max., 8 ea.
3. Stainless steel hose clamps — 1-1/4 in. max., 24 ea.
4. TV-type U bolts — 1-1/2 in., 6 ea.
5. U bolts, galv. type: 5/16 in. X 1-1/2 in., 4 ea.
6. U bolts, galv. type: 1/4 in. X 1 in., 2 ea.
7. 1 in. ID water-service polyethylene pipe 160 lb/in.² test, approx. 1-3/8 in. OD, 7 lin. ft
8. 1-1/4 in. X 1-1/4 in. X 1/8 in. aluminum angle — 6 ft lengths, 12 lin. ft
9. 1 in. X 1/4 in. aluminum bar — 6 ft lengths, 6 lin. ft
10. 1-1/4 in. top rail of chain-link fence, 26.5 lin. ft
11. 1:1 toroid balun, 1 ea.
12. No. 6-32 X 1 in. stainless steel screws, 8 ea.
No. 6-32 stainless steel nuts, 16 ea.
No. 6 solder lugs, 8 ea.
13. No. 12 copper feed wire, 22 lin. ft
14. 12 in. X 6 in. X 1/4 in. aluminum plate, 1 ea.
15. 6 in. X 4 in. X 1/4 in. aluminum plate, 1 ea.
16. 3/4 in. galv. pipe, 3 lin. ft
17. 1 in. galv. pipe — mast, 5 lin. ft
18. Galv. guy wire, 50 lin. ft
19. 1/4 in. X 2 in. turnbuckles, 4 ea.
20. 1/4 in. X 1-1/2 in. eye bolts, 2 ea.
21. TV guy clamps and eyebolts, 2 ea.

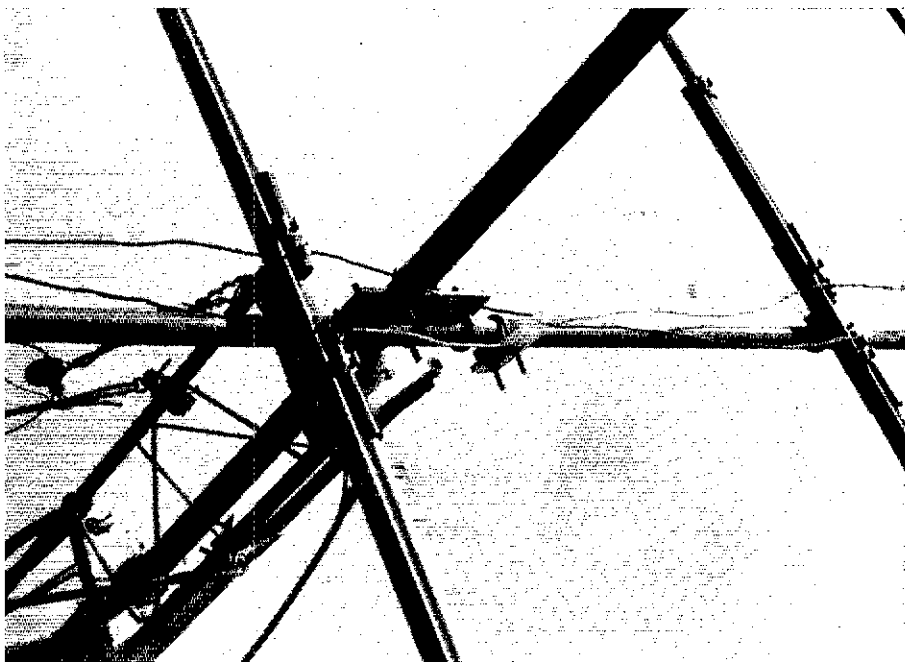

The interconnection between the elements of the log cell changes sides between each element.

7) Determine the parasitic element lengths (ft) and spacings (ft).

$$l_{REF} = \frac{509.6}{f_1 \text{ MHz}}$$

$$d_{REF} = \frac{84}{f_1 \text{ MHz}}$$

$$l_{DIR} = \frac{450.8}{f_1 \text{ MHz}}$$

$$d_{DIR} = \frac{148}{f_1 \text{ MHz}}$$

This completes the design.

The Finished Log-Yag

The proof is always to be found in the completed and operating product. The author's 14-MHz Log-Yag on-the-air performance on cw and ssb substanti-

ates the theory. The characteristics of the array are given in Table 1.

The materials needed are given in Table 3. In the construction diagram, Fig. 4, the materials are referenced by their respective material list number. The photographs show the overall construction picture, and the drawings show the details.

The materials should be available from most hardware and electronic stores. However, some have found difficulty in obtaining the aluminum tubing. This can be solved by writing to the manufacturer and asking for the name of their distributor nearest your locality. Commercial antenna manufacturers will sell their tubing, but the cost is at a premium.

This array is in operation at K4EWG and W4BBP. The results on the air are nothing short of fantastic! It will give the stacked Yagis and long-boom Yagis a run for their money.

It is the authors' hope that this antenna design will stimulate additional work and research by other amateurs.

The field seems wide open, and Yagi-Log combinations are endless. The optimum design is by no means achieved in this article. It does seem, however, that a log cell of more than four elements would be necessary only where the array bandwidths, B , exceed 1.03 ($B = f_n/f_1$).

The authors wish to thank George Smith, W4AEO, for his work in substantiating a consideration for log-periodic gain. QET

Bibliography References

- ¹ "The Swan Multidrive 2-Meter Antenna," *QST*, Oct., 1969.
- ² Orr, *Radio Handbook*, 18th edition, pp. 547-548.
- ³ Rhodes, "The Log-Periodic Dipole Array," *QST*, November, 1973.
- ⁴ *The ARRL Antenna Book*, 13th edition, p. 151.
- ⁵ See ref. 2 above, p. 558.
- ⁶ King, Mack and Sandler, "Arrays of Cylindrical Dipoles," *Yagi-Uda Programme Apdx. V*, 1968, pp. 213-232, 468-470.
- ⁷ See ref. 4 above, pp. 160-164, 208-210, and Fig. 9-18.
- ⁸ Smith, "Yes, I've Built Sixteen Log Periodic Antennas!" *73*, March, 1975. See pp. 98-99.
- ⁹ Orr, "Antennas," *CQ*, March, 1975. See section headed "The KLM Antenna."
- ¹⁰ See ref. 4 above, p. 204 and Fig. 9-5.

Strays



WHERE'S OSCAR?

□ Find out for the next year with an improved AMSAT-OSCAR orbital-data calendar. In cooperation with AMSAT, Skip Reymann, W6PAJ, has published the calendar containing information on all orbits for 1977. Designed so that it may be hung on a wall, the calendar has

information on the operating schedules and frequencies for both OSCARs 6 and 7 as well as telemetry decoding. Also included are step-by-step instructions on how to determine passage times by the two satellites.

The orbital calendar is available for \$5, postpaid, U.S. funds; 30 IRCs; \$3 to AMSAT members; and free to AMSAT Life Members. Overseas orders will be airmailed. Orders and payment should be made to Skip Reymann, P. O. Box 374, San Dimas, CA 91773.

For fast processing of your order, please include a gummed or self-adhesive, self-addressed label. Proceeds from the orbital calendar benefit AMSAT.

QST Congratulates . . .

□ Bernard Ostrofsky, W9HTF, on appointment as senior research associate in the Materials Research and Services Division of Standard Oil (Indiana), Naperville, IL.